

# BELT COVER & OIL RESERVOIR COMPONENTS

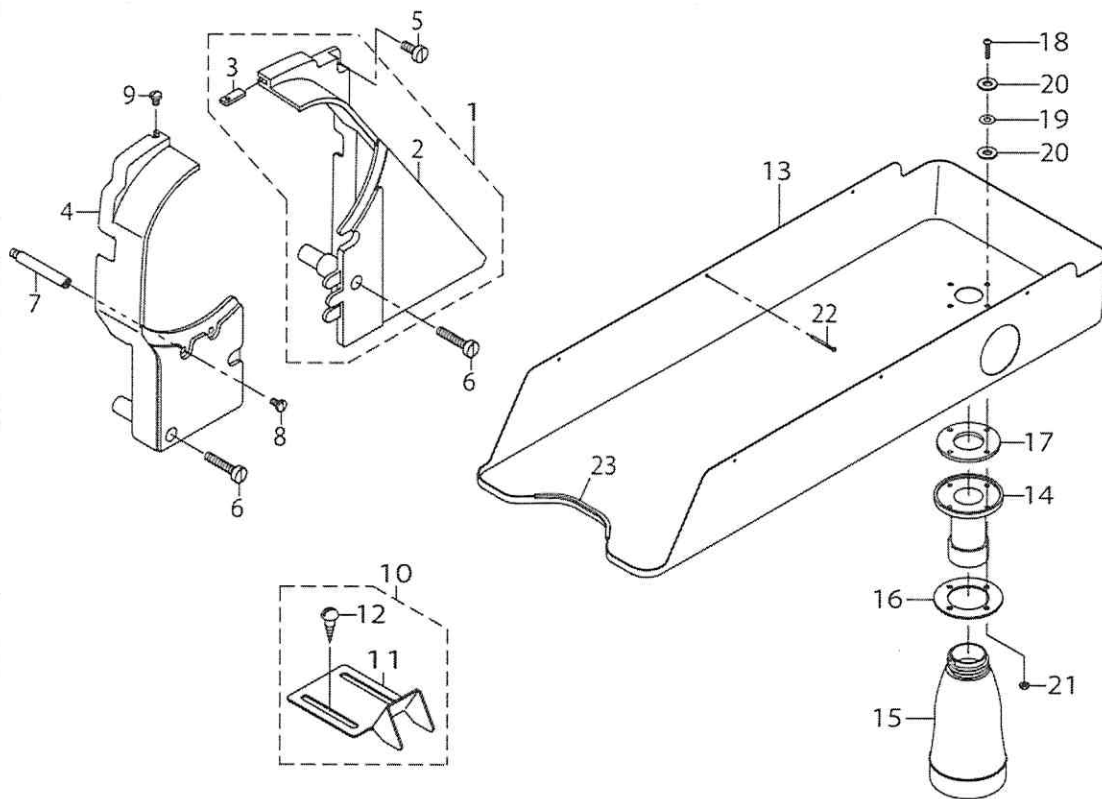

BELT COVER & OIL RESERVOIR COMPONENTS

No.	Supply Code	Parts No.	Replacement	Parts name	Remarks	Choice	Step	Level	Cons	Qty	Rep. QTY
1		21351150		BELT COVER ASM. (RIGHT)						1	
2	R	21351101	21351150	BELT COVER (RIGHT)				*		1	1.00
3		21351002		BELT COVER AUXILIARY PLATE				*		1	
4		21351200		BELT COVER (LEFT)						1	
5		SS6151440SP		SCREW 15/64-28L=14						1	
6		SS6153040SP		SCREW 15/64-28L=30						2	
7		D8232241E00		BELT COVER SUPPORT A						1	
8		SS7110840SP		SCREW 11/64-40 L=7.8						1	
9		SS5110740TP		SCREW 11/64-40 L= 6.5						1	
10		10755254		BELT COVER C ASM. (FOR JE)						1	
11		10755205		BELT COVER C(JE)				*		1	
12	R	SK3482500SC	SK3482501SE	WOOD SCREW D=4.8 L=25				*		2	1.00
13		21413000		OIL RESERVOIR						1	
14		B8202205000		OIL MANAGEMENT						1	
15		B9121012000		OIL CAN						1	
16		21379003		OIL MANAGEMENT WASHER						1	
17		B8112220000		OIL SEAL						1	
18		SM3031401SE		SCREW M3X0.5 L=14						4	
19		WP0320501SC		WASHER M3						4	
20		10748101		OIL REMOVING SET- SCREW PACKING						8	
21		NM6030001SC		NUT M3						4	
22		10539906		SET NAIL						6	
23	D	MAV02130000		EDGING						1	